

Super Discone Antenna

D150

For Reception 50-1500MHz Wide-Band Non-Directional Antenna

(Available for transmitting for the range 50/144/430/904/1200MHz band)



Operation Instructions

To use this antenna properly, read this instructions thoroughly before using the antenna. Keep this manual carefully at hand for later use.



PASSION-RADIO.FR

Analogique - Numérique - SDR

Check for the parts

Hexagonal wrench for M4



Washer

spring washer

Nut(M4)

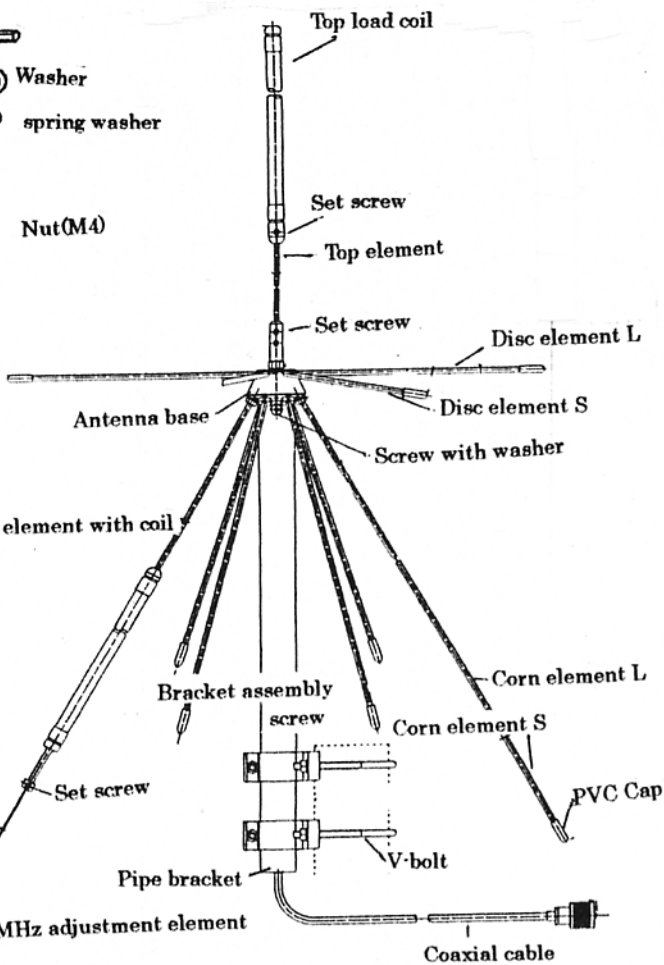

How to Assemble

For assembling, plus driver, 7mm spanner, 8mm spanner will be necessary.

Assemble the cone element(S, L, Coil)

1. Remove the upper position screw of pipe bracket by plus screw driver and remove the cone base from pipe bracket.

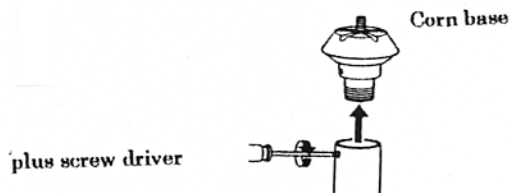

2. Attach the nut to the cone element. The nut should be fastened to the end of screw tap.

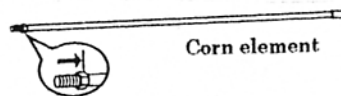

3. Attach the cone element and spring washer to the cone base. After setting by hand then fasten firmly by 7mm spanner. Fix the cone element with cone and 50MHz adjustment element with a set screw. Pull out the element 140mm.

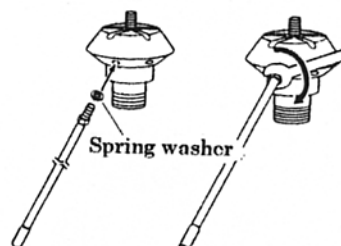
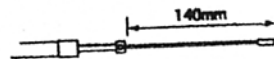

4. All 6 pieces of cone elements should be mounted.
(Note) Mount the cone element L and cone elements with coil 180 degree opposite position.



PASSION-RADIO.FR

Analogique - Numérique - SDR

DIAMOND ANTENNA CORPORATION

Miyata Building, No. 15-1, 1-chome Sugamo, Toshima-ku Tokyo, Japan 170-0002 TEL.03-3947-1411 FAX.03-3944-2981

Home Page <http://www.diamond-ant.co.jp>

Super Discone Antenna

D150

For Reception 50-1500MHz Wide-Band Non-Directional Antenna

(Available for transmitting for the range 50/144/430/904/1200MHz band)

Mounting of Disk Element(S, L)

1. Put the plane washer onto the screw at the top of disk base.

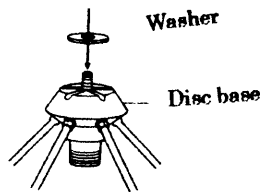

2. Hold the plane washer with finger insert the disk element to the end of slit of disk base. The disk element is provided with marker point to stop the insertion. (Note) Mount the 2 disk elements 180 degree opposite position.

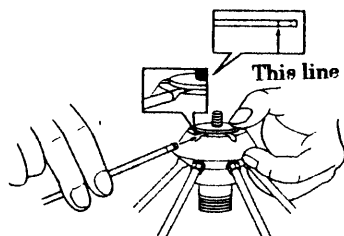

3. After setting the 6 pieces of disk elements, put the spring washer into the screw at top of disk base.

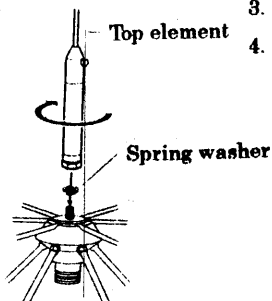

1. Mount the top element to the screw at top of disk base and fasten with 8mm spanner. Check the mounting condition of disk elements.

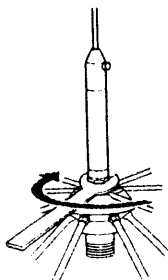

Mounting bracket assembly

1. Thread the pipe bracket through mounting bracket and fix the bracket at the position of sticker seal by plus driver.
2. Fix other mounting bracket onto the specified position with seal keeping 60mm space from above mounting bracket.

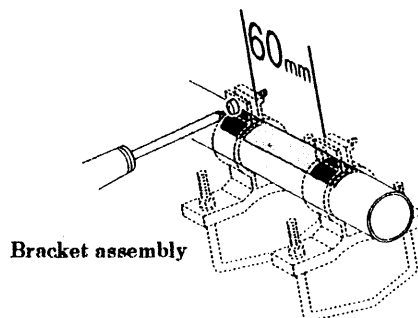

Mounting the antenna and pipe bracket

1. Thread the coaxial cable through pipe bracket from lower side.
2. Connect the coaxial cable connector to the feeding part, lower part, of cone base firmly.
3. Insert the cone base into the pipe bracket.
4. Adjust the position of the holes of both cone base and pipe bracket and fasten the set screw removed from pipe bracket first together with teeth washer by plus driver.

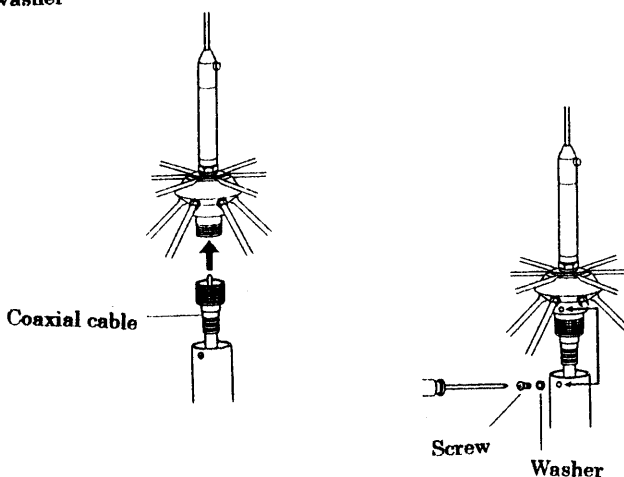

PASSION-RADIO.FR

Analogique - Numérique - SDR

DIAMOND ANTENNA CORPORATION

Miyata Building, No. 15-1, 1-chome Sugamo, Toshima-ku Tokyo, Japan 170-0002 TEL.03-3947-1411 FAX.03-3944-2981

Home Page <http://www.diamond-ant.co.jp>

Super Discone Antenna

D150

For Reception 50-1500MHz Wide-Band Non-Directional Antenna

(Available for transmitting for the range 50/144/430/904/1200MHz band)

How to Mount the Antenna

D150 can be mounted to the mast with diameter 25-50mm. Select the mast and length to get the optimum condition and mount the antenna by "V" bolt firmly. Regarding cable, it is better to make 1 turn of cable under the antenna and fix it by vinyl tape. The antenna must be set up keeping the vertical angle.

(Note) The mast and poles are sold separately.

Operation Check

To use as reception, D150 is not necessary to adjust before use. But after setting up the antenna, check the operation. In case the transceiver is connected D150 (without transmission 50MHz band use), check the VSWR in the range of transmitting frequency. When connecting the receiver, receive the actual signal wave and check the receiving sensitivity. When the VSWR is high or receiving sensitivity is lower, check the antenna assembly again and connections. In the meantime, the 50MHz band should be adjusted below instruction.

(Note) The 50MHz band is no need to adjust with reception only.

How to adjust the 50MHz band

For using the antenna 50MHz transmission, You must adjust the top element.

Default is adjusted around 51MHz frequency

The desired frequency can be adjusted by the 50MHz band adjustment element length. With longer element size, the frequency will move to lower side and shorter length move the frequency to higher level. The frequency change per 1cm length is 500MHz.

(Note) Standard L=140mm

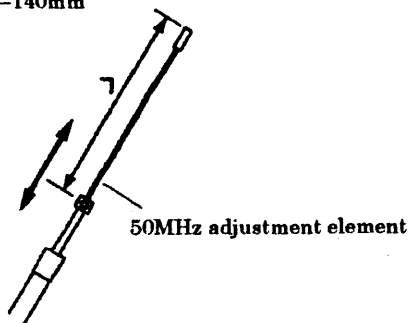

Specifications

| | |
|-------------------------|---|
| Frequency | : 50-1500MHz Reception 50/144/430/1200MHz & 904MHz Transmission |
| Impedance | : 50 Ω |
| VSWR | : Less than 1.5 (* 50MHz in Resonance Frequency) |
| Max power rating | : 50W FM (* 50MHz 30W) |
| Rated Wind Velocity | : 40m/sec. |
| Mast diameter accepted: | : ϕ 25 - ϕ 50 |
| Length | : 1.04 m |
| Max Diameter | : About 58cm |
| Weight | : 0.62 Kgs. (Antennas Only) |
| Coaxial Cable | : RG58/U 10m with MP connector |
| Connector | : M (M-J) |



PASSION-RADIO.FR

Analogique - Numérique - SDR

Others

When changing the coaxial cable, Check the impedance of 50 ohm and diameter maximum 10DFB.

DIAMOND ANTENNA CORPORATION

Miyata Building, No. 15-1, 1-chome Sugamo, Toshima-ku Tokyo, Japan 170-0002 TEL.03-3947-1411 FAX.03-3944-2981

Home Page <http://www.diamond-ant.co.jp>

Super Discone Antenna

D150

For Reception 50-1500MHz Wide-Band Non-Directional Antenna

(Available for transmitting for the range 50/144/430/904/1200MHz band)

FOR YOUR SAFETY

Read the following safety precautions before starting assembling the antenna.

- Assemble the antenna on the ground or wide and flat place such as on balcony before installation.
- Do not assemble or install the antenna on a place where you can not have enough distance from any electric power lines.
- Do not attempt to install the antenna only by yourself. Installing the antenna alone on the roof may lead you dangerous accident. Always ask your friends for help installing the antenna.
- Do not use iron or aluminum ladder at a reachable distance from any electric power lines.
- Do not install the antenna on a mast which is not grounded properly.
- Do not have your family members or friends touch or come close to the antenna, unless they have realized its potential danger.

TO AVOID FATAL ACCIDENT

- Do not attempt to sustain the antenna, or any part of support structure if it begins to fall down. Let it fall by itself.
- Do not attempt to remove or restore the antenna or any part of support structure if it touches a electric power line by chance. Let it be as it is, do not touch it, and call your local electric power company immediately.

IN CASE OF AN ACCIDENT

- Do not touch a person or an animal who is or seems to be in contact with the antenna or any support structure which is fallen on a live electric power line. Touching one may lead you to be electrocuted.
- Do not attempt to separate a person or an animal who is or seems to be in contact with the antenna or any support structure which is fallen on a live electric power line by yourself. Call or have someone call a police officer, ambulance, doctor immediately.

ANTENNA INSTALLATION PRECAUTIONS

To determine antenna installation location, there are several factors to be taken into account. First thing is antenna propagation direction to specific target stations. As to whether there is any obstacles such as tall buildings on the line of sight. Next is specific installation location. As to whether specific location is adequate in terms of antenna support and surrounding safety.

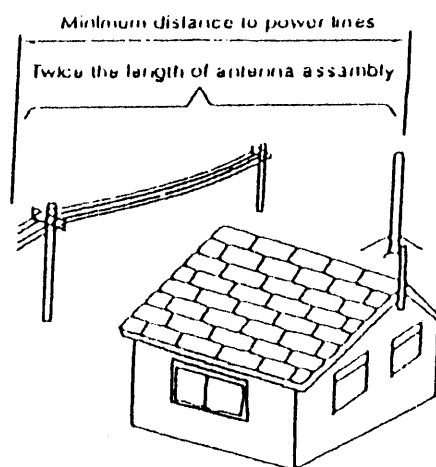

- Do not attempt to install the antenna by yourself if you do not have any experience in installing base station antenna. Ask your experienced friends or professional for help.
- Do not attempt to install the antenna at a location where does not have enough distance from nearby electric power lines. It is advised to install the antenna at least twice of total antenna height from nearby electric power lines.
- Do not install the antenna on any type of tower pole or telescopic mast which exceeds 30 feet high, if you do not have enough experience in installing the antenna on that kind of location. Ask your experienced friends or professional for help.
- Do not use more than 1/10 section if you install the antenna on iron plumber's pipe. Attach guy wire if multiple pipes are used to install the antenna.



PASSION-RADIO.FR

Analogique - Numérique - SDR

DIAMOND ANTENNA CORPORATION

Miyata Building, No. 15-1, 1-chome Sugamo, Toshima-ku Tokyo, Japan 170-0002 TEL.03-3947-1411 FAX.03-3944-2981

Home Page <http://www.diamond-ant.co.jp>